

All Vertical Parts

1 = 1.5" x 1.5" x 60.0" square  
 2 = 2.00" x 2.00" x 54.00" square w/telescopic  
 3 = refer to WheelBase -

Qty

5  
 2

Horizontal Parts (refer to Front View)

H1 = 1.5" x 1.5" x 41.50" square  
 H2 & H3 = 1.5" x 1.5" x 23.50" U channel

Qty

1  
 2

Notes:

Materials used = mild steel  
 Tubing material thickness = 0.063"

Over all Width = 30.00" +0.00, - 0.13"  
 Overall Length = 50.55 + wheel arms  
 Overall Height = 60.00 + wheelbase hgt + telescopic

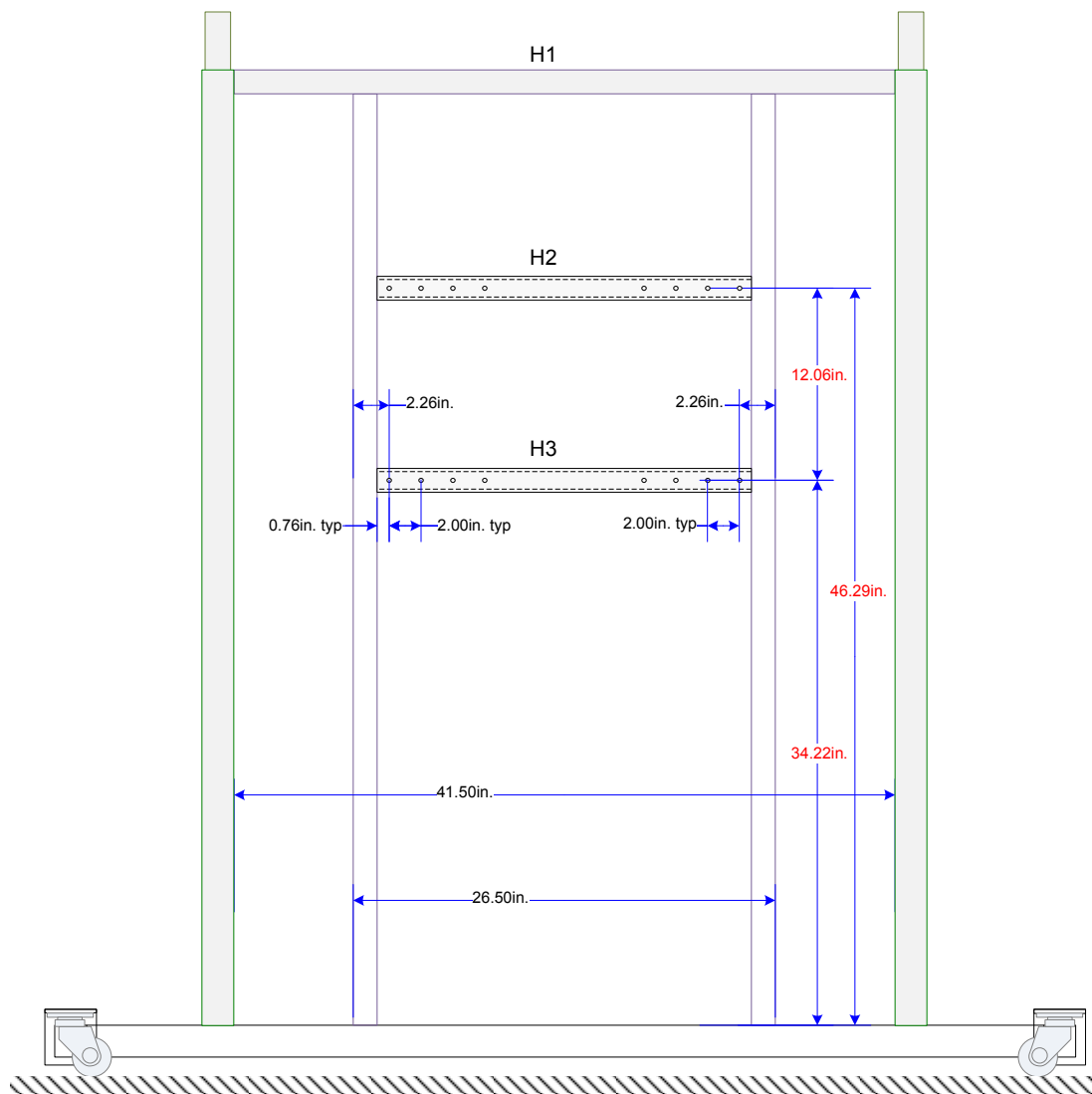
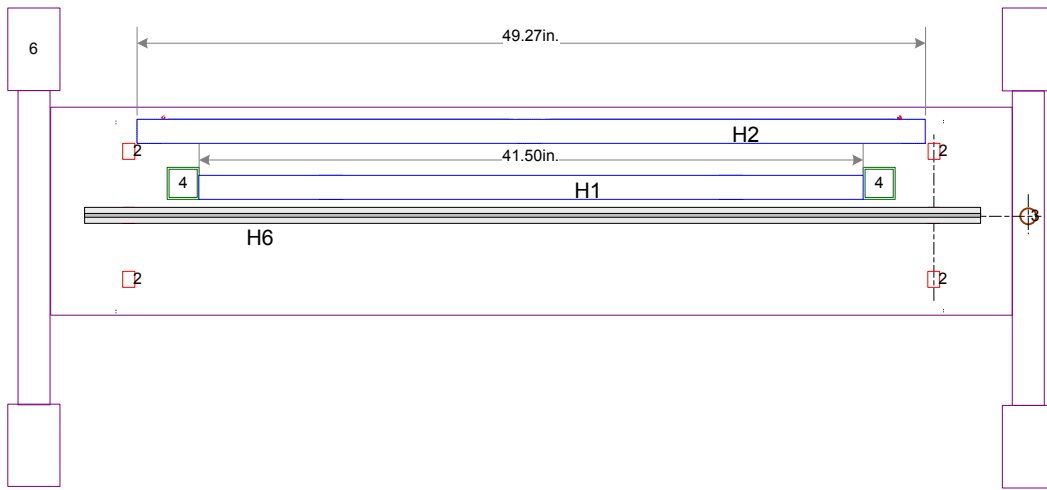

Horizontal Parts

H1 = 1.5" x 1.5" x 41.50" square

H2 & H3 = 1.5" x 1.5" x 23.50" U channel

Qty

1

2

## H2 and H3

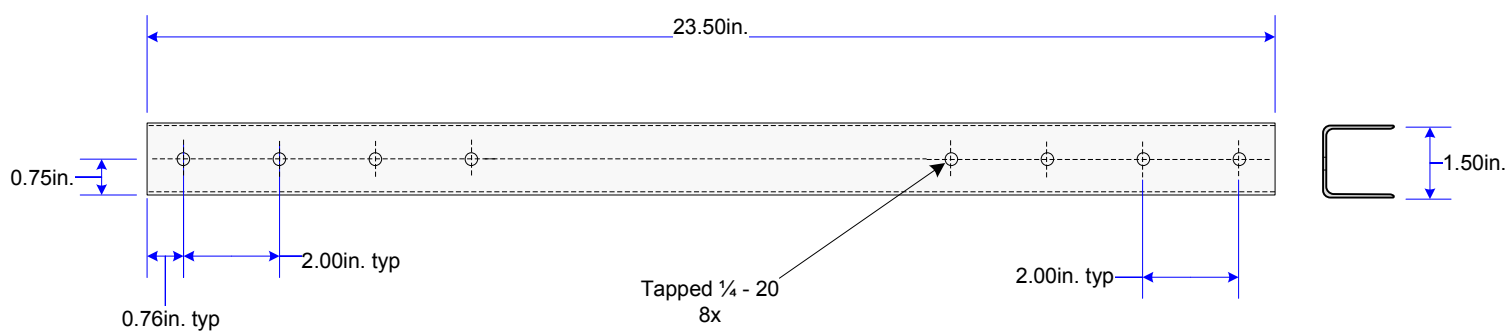

H2 & H3 = 1.5" x 1.5" x 23.50" U channel, Qty 2 pcs.

